



Engine	Yuchai YC6J125Z-T22
Rated Power	92 kW (123 hp / 125 ps) @ 2,000 rpm
Net Power	85 kW (114 hp / 116 ps) @ 2,000 rpm
Operating Weight	10,125 kg
Standard Bucket Size	1.8 m ³
Standard Breakout Force	102 kN
Standard Dump Clearance	2,938 mm

835HE WHEEL LOADER

835HE SPECIFICATIONS >>>

ENGINE

Emission Regulation	Tier 2 / Stage II
Maker	Yuchai
Model	YC6J125Z-T22
Rated Power	92 kW (123 hp / 125 ps) @ 2,000 rpm
Net Power	85 kW (114 hp / 116 ps) @ 2,000 rpm
Peak Torque	608 N·m @ 1,300-1,500 rpm
Displacement	6.494 L
Number of Cylinder	6
Aspiration	Turbocharged

TRANSMISSION

Transmission Type	Planetary, power shift
Torque Converter	Double stage, four elements
Maximum Travel Speed, fwd	36 km/h
Maximum Travel Speed, rev	16 km/h
Number of Speed, fwd	2
Number of Speed, Rev	1

AXLES

Differential Front Type	Conventional
Differential Rear Type	Conventional
Axle Oscillation	±10°

STEERING

Steering Configuration	Articulated
Steering Relief Pressure	17.2 MPa

BRAKES

Service Brake Type	Caliper discs brake
Service Brake Actuation	Air over hydraulic
Parking Brake Type	Caliper discs brake
Parking Brake Actuation	Mechanical

HYDRAULIC SYSTEM

Main Pump Type	Gear
Main Relief Pressure	22 MPa
Raise	5.5 s
Dump Time	1.1 s
Float Down Time	3.1 s
Fastest Total Cycle Time	9.7 s

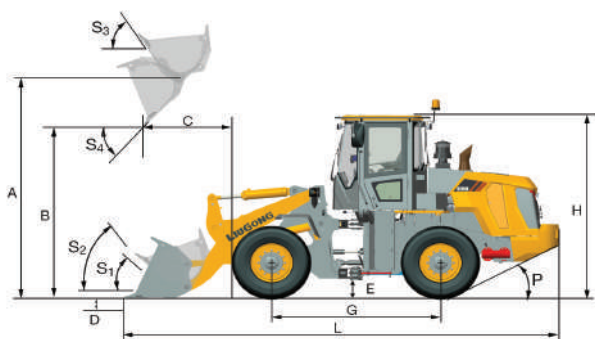

LOADER ARM PERFORMANCE with Standard Bucket 1.8 m³

Tipping Load - Straight (ISO 14397-1:2007)	7,800 kg
Tipping Load - Full Turn (ISO 14397-1:2007)	6,700 kg
Bucket Breakout Force	102 kN
A Maximum Hinge Pin Height	3,739 mm
B Dump Clearance at Full Height Discharge	2,938 mm
C Dump Reach at Full Height Discharge	1,042 mm
D Maximum Digging Depth, Bucket Level	40 mm
S ₁ Rollback at Ground Level	42°
S ₂ Bucket Rollback at Carry	49°
S ₃ Bucket Rollback at Maximum Height	60°
S ₄ Maximum Dump Angle at Full Height	45°

BUCKET PERFORMANCE

Reference Bucket	1.5-3.2 m ³
------------------	------------------------

DIMENSIONS

E Ground Clearance	350 mm
G Wheelbase	2,870 mm
H Cab Height	3,340 mm
J Wheel Tread	1,850 mm
K Width Over Tires	2,295 mm
L Length with Bucket Down	7,193 mm
M Turn Angle, Either Side	40°
P Rear Angle of Departure	28°
R ₁ Turning Radius, Bucket Carry	5,616 mm
R ₂ Turning Radius, Outside of Tire	5,090 mm
W Width Over Bucket	2,500 mm

TIRES

Tire Size	17.5-25PR12
-----------	-------------

OPERATING WEIGHTS

Operating Weight	10,125 kg
------------------	-----------

SERVICE CAPACITY

Fuel Tank	140 L
Engine Oil	17 L
Cooling System	35 L
Hydraulic System	100 L
Transmission and Torque Converter	40 L
Axles, Each	22 L

